

THE NEXT STEP

03.10.2010

2010 ICCFA ANNUAL CONVENTION & EXPOSITION
HENRY B. GONZALEZ CONVENTION CENTER • SAN ANTONIO, TX
MARCH 10-13, 2010



**Don't delay! The ICCFA 2009 Exposition sold out.
Reserve your 2010 booth space now!**

THE NEXT STEP

Take the Next Step! The ICCFA Annual Convention & Exposition, March 10-13, 2010, at The Henry B. Gonzalez Convention Center is your best opportunity of the year to connect with hundreds of cemetery, cremation and funeral service owners and managers from all over North America and around the world.

Meet Industry Decision Makers!

What makes the ICCFA Expo so successful? It's the extra effort we make to ensure you have a productive and profitable show. For years, the ICCFA has worked closely with our exhibitors to build an event around your needs ... one that brings in the best prospective customers, and keeps them in the Expo Hall so you can make the connections you need.

Nowhere else will you find such a concentration of decision makers who are actively looking for ways to grow their businesses. A remarkable 98 percent of our attendees have a say in their companies' purchases, with the majority holding final purchasing authority. What's more, more than half represent companies that own more than one facility ... so your sale often extends beyond a single location. Check out our stats, and you'll see why the ICCFA Expo is the fastest-growing, highest-rated exhibition in our industry.

Who Attends the ICCFA Convention

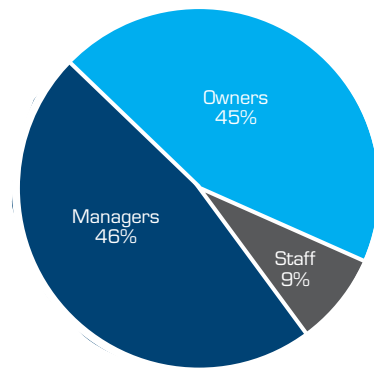

Decision Makers Attending ICCFA Convention

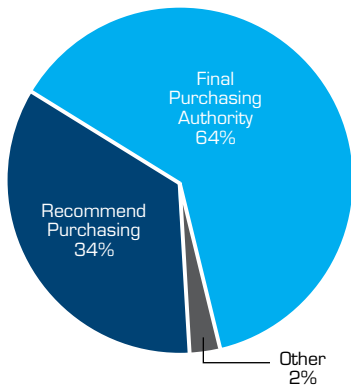

"I Make Purchasing Decisions Based on ICCFA Exhibits"

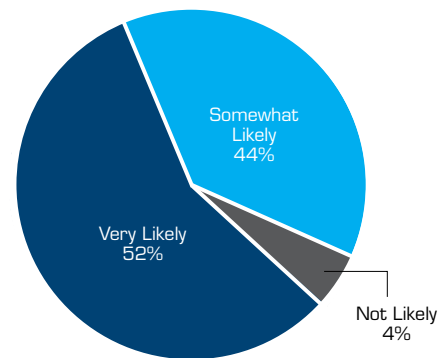

Convention Attendance By Company Type

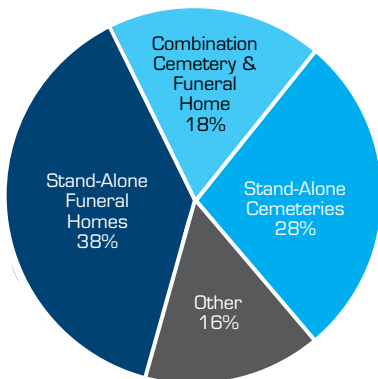

ICCFA Convention Exhibitors

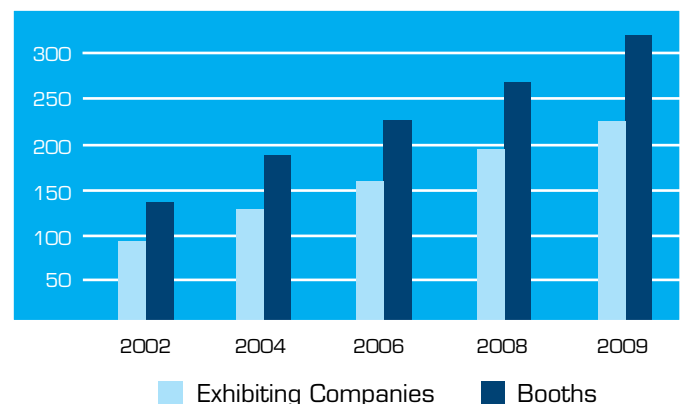

ALL EXPOS ARE NOT CREATED EQUAL

- The ICCFA Expo is the only national trade show that keeps growing! While trade shows throughout our industry and across all industries are struggling, the quality of the ICCFA Expo and the ICCFA Convention educational programming and the exceptional word-of-mouth buzz our show attracts has kept our attendance high. In 2009, we shattered our previous attendance records, and we expect our numbers to continue escalating in 2010 and beyond.
- Our show is specifically designed to attract buyers into the Expo Hall and keep them there. We hold no competing programming during Expo hours, and we provide continuous free food and beverage service throughout. This is unique to the ICCFA show, and our exhibitors thank us year after year for this attention to detail.
- ICCFA's Annual Convention & Exposition is the only industry event that combines all aspects of the profession—cemetery and funeral service management, cremation and memorialization. And this year, our newly formed Pet Loss Professionals Alliance is expanding our programming to include an educational track for pet death care providers. More than any other event in our industry, the ICCFA show attracts decision makers from independent cemeteries, funeral homes, crematories, and now pet death care providers, from North America and abroad.
- For the tenth consecutive year, all of our Convention general sessions will be held in the same room as the ICCFA Expo. This format benefits attendees and exhibitors alike, as it allows for continuous, highly productive networking.
- Our exhibitor satisfaction rate is the best in the industry. Exhibitors who participated at our Expo in 2009 rated that show an average of 8.3 on a scale of 1 to 10 and named it our most successful Exposition ever.

"Your show was wonderful. Very productive for our company. We cannot wait for the next one!"

— Christopher Isabella, DoubleBridge Technologies

Exhibit Hall Schedule

Tuesday, March 9

8 am - 5 pm

Move-In/Set-Up

Wednesday, March 10

8 am - 4 pm

Move-In/Set-Up

4 - 5:30 pm

Show Management Inspection

5:30 - 6 pm

First Timers Reception

6 - 8 pm

Grand Opening Reception

Thursday, March 11

11 am - 2 pm

Lunch at the Expo

5 - 7 pm

IMSA Exhibitor's Reception

Friday, March 12

12 noon - 3 pm

Lunch with Exhibitors

3 - 7 pm

Teardown/Move-Out



BOOTH INFORMATION

What does your booth price include?

Your booth rental provides your company's representative(s) with exclusive admission to the Expo Hall and all Expo functions as well as all Convention educational sessions and non-ticketed functions. In addition, it includes:

Non-Competitive Expo Hours. ICCFA schedules no educational sessions during Expo hours to ensure that you will have every buyer's undivided attention.

Attendee Directories. Exhibitors receive directories of contact information for all Convention attendees as part of their booth fee. **Other associations charge hundreds of dollars for attendee lists, but we know this is an integral part of your marketing effort and can be crucial to the success of your show.** Several weeks prior to the Convention, we'll provide an electronic file (in Excel) to allow you to conduct promotional mailings to those who have pre-registered. Onsite, you'll receive a physical directory of all attendees. And after the Convention, you'll receive another, updated Excel file for your post-Convention mailings.

Free Food and Beverage Service. The ICCFA provides free food and beverage service throughout all Expo functions to encourage attendees to stay in the hall and visit every booth. Exhibitors often ask whether they are welcome to this service as well. The answer: Absolutely ... please enjoy!

Listing in ICCFA Magazine. Your company will be highlighted in a special section of the March/April onsite edition of ICCFA Magazine, including your product description and your booth number. This issue receives wide distribution both at the Convention and through the mail to 7,200 ICCFA Magazine readers. Please note that you must submit your Booth Space Application & Contract and your Exhibitor's

Profile (see pages 11-12) before January 15, 2010, for inclusion in this listing.

Listing on the ICCFA Web site. Your company will be included in our exhibitor listing on the ICCFA Web site, including a link to either your company's profile on the ICCFA site or to your home page, if you have one.

Exhibitor's Directory Listing. All attendees receive a directory of exhibiting companies. Be sure to submit your Booth Space Application & Contract by February 1, 2010, to ensure your inclusion in the directory!

Registration for Exhibitor Personnel. Your company will receive two complimentary registrations per booth purchased. Registrations include admission to the Expo Hall and all Expo functions as well as all non-ticketed Convention educational sessions and functions. (Please note that this does not include ticketed functions noted as such on the Exhibitor Personnel form. You may purchase individual tickets for those functions.)

Draping and Signage. Your booth space will be framed with an 8'-high back drape and 36"-high side rails. You'll also receive a 7" x 44" booth identification sign showing your company name, booth number and membership status in the ICCFA and the IMSA, if applicable. (Any alterations made to the standard 8' height dimension, where permitted, will be at the exhibitor's own expense.)

Security Guard Service. The ICCFA contracts for 24-hour security from move-in through move-out. Note that we do not guarantee against loss or damage.

Exhibitor Magazine Names ICCFA Expo a 'Highlight'

Not only do our exhibitors and attendees appreciate the success of the ICCFA Expo, Exhibitor Magazine this year spotlighted our event for its atmosphere and attendance. At a time when the trade show industry is struggling, the June 2009 issue of Exhibitor Magazine named the ICCFA Expo a "highlight" of the "exhibition experience."

Editor Travis Stanton wrote: "Whoever came up with the idea of scattering open bars and food stations throughout a show

floor should win the Nobel Prize. ...having snacks and refreshments available in the exhibit hall...not only attracted a decent number of attendees but kept the mood lively and upbeat. ..."

The ICCFA offers continuous free food and beverage service for attendees and exhibitors throughout all Expo hours, making sure your potential customers remain in the hall and enjoy the overall Expo experience.



EXHIBIT HALL A FLOORPLAN

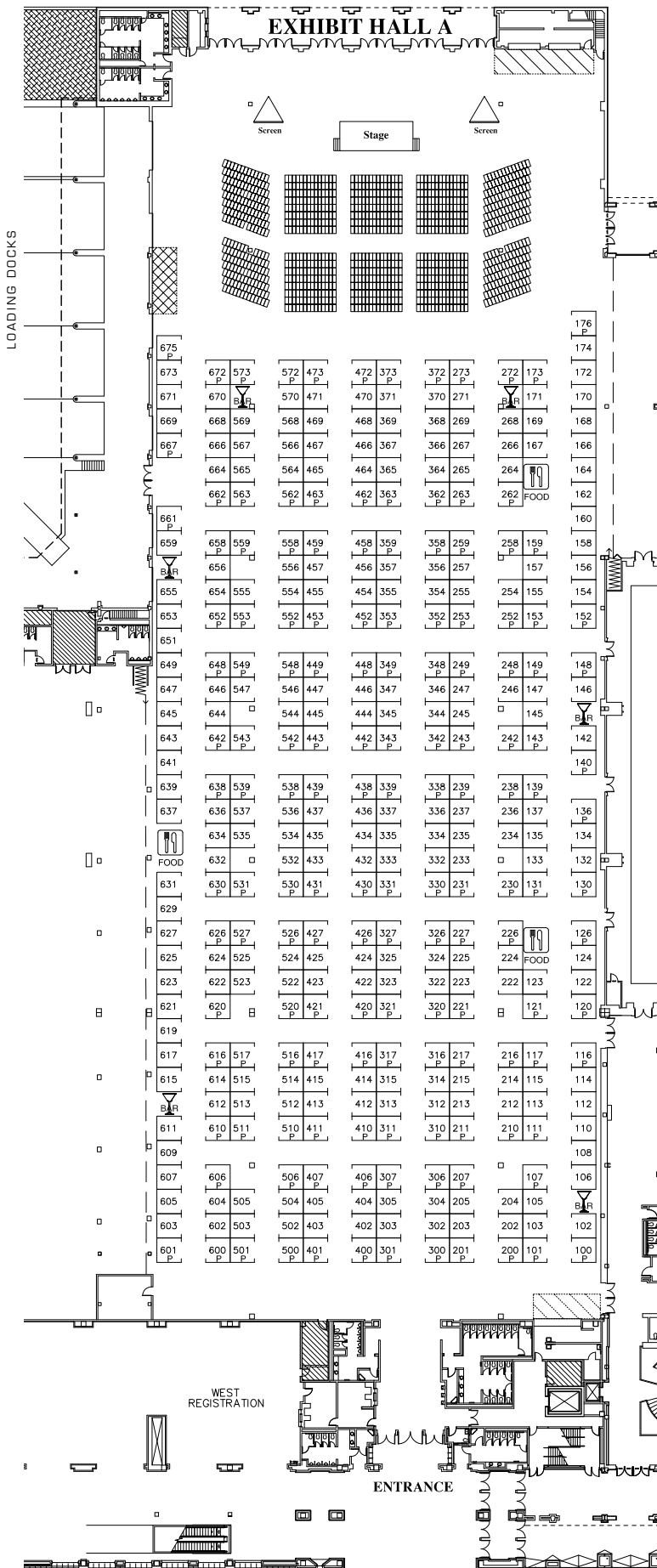

Booth Prices

10' x 10' Conventional Booth

ICCFA Member: \$1,095
 Non-Member: \$1,395

10' x 10' Premier Booth

ICCFA Member: \$1,395
 Non-Member: \$1,695



"ICCFA is the best industry Expo we attend. The best attendees! Decision makers attend, making it easy to do business at the show, and food service during the exhibit hours keeps attendees at the Expo."

— Joanna Passarelli, ECoFFins USA

BOOTH SPECIFICATIONS

Standard Booths

Standard Booths have only one side exposed to an aisle and are generally arranged in a series along a straight line. They are also called "in-line" booths. Standard Booths are 10' wide and 10' deep. A maximum back wall height limitation of 8' is specified. Regardless of the number of Standard Booths utilized (e.g. 10' x 20', 10' x 30', 10' x 40', etc.), display materials should be arranged in such a manner so as not to obstruct sight lines of neighboring exhibitors. The maximum height of 8' is allowed only in the rear half of the booth space, with a 4' height restriction imposed on all materials in the remaining space forward to the aisle. (Note: When three or more Standard Booths are used in combination as a single exhibit space, the 4' height limitation is applied only to that portion of exhibit space which is within 10' of an adjoining booth.)

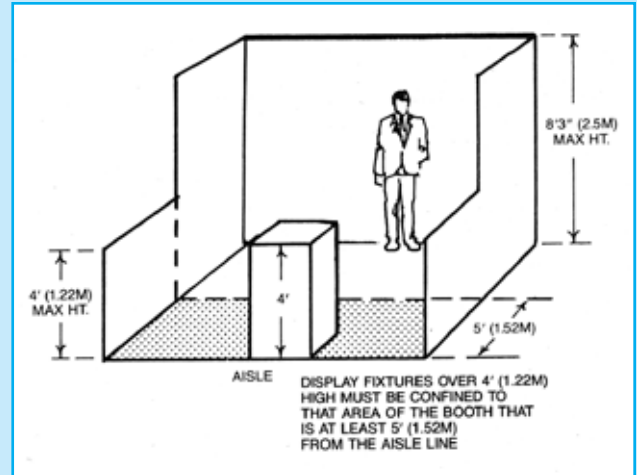

Corner Booths

A Corner Booth is a Standard Booth exposed to aisles on two sides. All other guidelines for Standard Booths apply.

Island Booths

An Island Booth is four or more Standard Booths exposed to aisles on all four sides. It may or may not have a second story, as depicted here. An Island Booth is typically 20' x 20' or larger, although it may be configured differently. A maximum height of 16', including signage, will be permitted based on ICCFA Show Management receiving a written proposal 60 days prior to the show.

Sufficient see-through areas must be provided to prevent blocking views of adjacent exhibits.

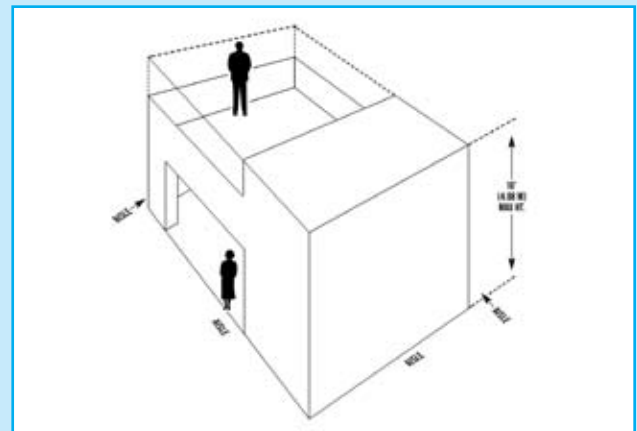

Perimeter Booths

A Perimeter Booth is simply a Standard Booth that backs to a wall of the exhibit facility rather than to another exhibit. All guidelines for Standard Booths apply to Perimeter Booths except that the typical maximum backwall height is 12'. (This height determination is further restricted by the ceiling height of the exhibit hall.) No solid exhibit construction at the sides may exceed 4' in height, except the rear one-half of the booth.

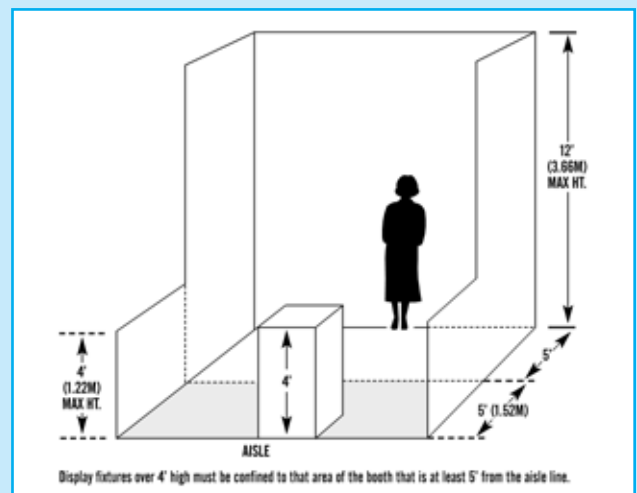

Peninsula Booths

A Peninsula Booth is exposed to aisles on three sides and composed of a minimum of four booths. It may or may not have a second story as depicted here. A Peninsula Booth is usually 20' x 20' or larger. When a Peninsula Booth backs up to two Standard Booths, the backwall is restricted to 4' high within 5' of each aisle, permitting adequate line of sight for the adjoining Standard Booths. A maximum height of 16', including signage for center portion of the backwall, will be permitted based on ICCFA Show Management receiving a written proposal 60 days prior to the show. Peninsula Booth is exposed to aisles on three sides and composed of a minimum of four booths. It may or may not have a second story as depicted here. A Peninsula Booth is usually 20' x 20' or larger. When a Peninsula Booth backs up to two Standard Booths, the backwall is restricted to 4' high within 5' of each aisle, permitting adequate line of sight for the adjoining Standard Booths. A maximum height of 16', including signage for center portion of the backwall, will be permitted based on ICCFA Show Management receiving a written proposal 60 days prior to the show.

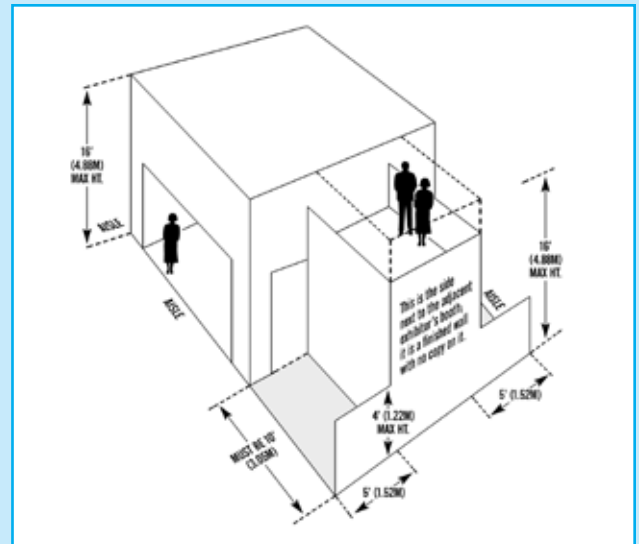

Booth Applications & Assignments

Applications for booth space are to be made using the forms on pages 11 and 12 and are to be accompanied by a non-refundable deposit. No requests for exhibit space will be accepted by telephone. All applications received by December 1, 2009, will be assigned on a cumulative point system. (See Rules of the Expo on page 9.) Notification of assignments will be mailed in January for all applications received by December 1. Applications received after December 1 will be assigned on a first-come, first-served basis as space permits, after initial assignments have been made. In order to complete the assignment process on time, the ICCFA cannot call exhibitors if their request for space is not available. Booth assignments may be changed by the International Cemetery, Cremation and Funeral Association only with prior approval of the exhibitor. If circumstances beyond the control of the ICCFA require a re-assignment, the ICCFA will consult with the exhibitor

to locate an alternative space. The ICCFA will have final authority on booth assignments.

Booth assignments will be made based on the number of points a company (whose form is received by December 1) has accumulated, giving first preference to companies with the greatest number of points. In the event two or more companies with the same number of points request the same space, preference will be given to the company whose application was received first in the ICCFA office. If booth applications are received on the same day, preference will be given to the company exhibiting with the ICCFA the most number of years since 1970. A copy of total points accrued from 1970 to the present is available from the ICCFA upon written request. The ICCFA reserves the right to assign space to companies requesting a large number of booths in a manner that ensures maximum efficiency.



“Exhibiting times were great, attendance was great, speakers were great! It was the best ICCFA Convention yet, and we look forward to exhibiting next year!”

— Suzanne DeRouchie, Trigard

EXPO HALL SPECIFICATIONS

This Exhibitors' Prospectus is part of the Booth Space Application & Contract for the 2010 ICCFA Annual Convention & Exposition. Each exhibitor agrees to meet any applicable requirements of the federal, state and municipal governments, police and fire departments of the city and the management of the building, and to obtain and pay for all necessary permits and licenses, should any be required for the display of the particular exhibit. Each exhibitor shall be responsible for collecting and/or paying all applicable local, state and federal taxes.

Location. The Expo Hall is Exhibit Hall A at the Henry B. Gonzalez Convention Center, 200 E. Market St., San Antonio, TX 78205. All general sessions and food functions will be held in Exhibit Hall A.

Service Kits. Exhibitors' Service Kits, listing available services, electrical equipment, booth furniture and decorating materials, together with forms, will be emailed to exhibitors in February. The completed forms should be returned to the appropriate service company by the specified date. Please be sure to include your email address on the application form.

Carpet. Exhibit Hall A is not carpeted. Carpet order forms will be available in your service kit.

Ceiling Heights. The ceiling height within the hall is 24'.

Official Show Colors. The official show colors will be dark blue and black (the colors of the "Next Step" logo).

Decorator. ICCFA's official decorator for the 2010 Annual Convention and Exposition is George Fern Co. Our contact is Maggie Lewis at 615.256.0357
mlewis@georgefern.com

Dismantling. All exhibits must be removed from the exhibit area by the exhibiting company at its own expense no later than 7 p.m. on Friday, March 12. If an exhibitor fails to remove its exhibit on this day, the ICCFA may remove such exhibit to a storage warehouse at the expense of the exhibitor, who shall pay any damages or expenses incurred by the Association in removing the exhibit.

Loading/Unloading. Exhibitors do not have access to the loading docks at the Convention Center. You are strongly encouraged to utilize the services of George Fern Co. and their official freight company for shipment of material because they are the only ones who will have access to the docks. George Fern will provide more specific information in their service kit, which

will be available in February. Please contact Maggie Lewis at 615.256.0357 if you have any questions about how to ship your display.

Shipping Instructions. All materials must be shipped to and handled by George Fern Co. No exhibitor material will be accepted by the Convention Center or by the ICCFA, nor will the Association assume responsibility for loss of or damage to goods consigned or shipped to it. All goods must be plainly marked with the exhibitor's name and assigned booth number. Under no circumstances will goods be accepted on which there are charges due. Shipments should arrive no later than two weeks prior to the show in order to avoid late surcharges. For advance shipments, make out the bill of lading and consign as follows:

Name of Exhibiting Company _____

Booth Number _____

**Yellow Transportation
c/o George Fern Company
ICCFA Convention
111 Gembler Rd.
San Antonio, TX 78219**

No. of Pieces _____

Carrier _____

Travel and Accommodations. Our host hotel is the Grand Hyatt San Antonio. The ICCFA has obtained a discounted room rate for Convention attendees and exhibitors. The cut-off date for making reservations is February 18, 2010; however, please note that we expect our room block to sell out, and so we encourage you to make your reservations early. Please remember to identify yourself as an ICCFA attendee to obtain the discounted rate. For details, please see page 16 of this brochure.

Union Information. Exhibitors may set up their own booths with their own full-time employees. Teamsters Union claims jurisdiction on the erection, touch up, dismantling and repair of all exhibits when this work is done by persons other than your full-time employees. Decorators'

jurisdiction does not cover the placement of your products on display, the opening of cartons containing your products or the performance, testing, maintenance or repair of your products. Decorator has jurisdiction over unloading and loading trucks, trailers and common and contract carriers as well as the handling of empty crates and the operation of material handling equipment. Exhibitors may hand carry material if they do not use material handling equipment; they will not have access to loading docks or freight door areas if they do this.

Vehicles for Display. Exhibitors must take special measures to protect floors from damage. Any vehicles using hydraulic lifts, oil or gasoline must meet fire code regulations and visqueen must be placed underneath the vehicle to prevent soilage. Please contact George Fern Co. at 615.256.0357 for more information.

Floor/Weight Limitations. There is a 300-pounds-per-square-foot weight limitation in Exhibit Hall A.

Booth Assignments. The ICCFA assigns booths on a cumulative point system. Please see page 7 of the prospectus for details. Our goal is to separate competing companies to the best of our ability. In the best interest of our Exhibitors, there may be times when we need to ask a company to make a new booth selection to maintain this separation.

The ICCFA will have the final say in all booth placements.

Exposition Booth Prices

10' x 10' Conventional Booth

ICCFA Member:\$1,095

Non-Member:\$1,395

10' x 10' Premier Booth

ICCFA Member:\$1,395

Non-Member:\$1,695

RULES OF THE EXPO

Necessary regulations for the proper conduct of the exhibits as set forth herein are not considered all-inclusive, nor are they deemed or considered to be exclusive of such other reasonable rules and regulations as may or might become necessary to properly conduct this exposition. Such timely regulations and decisions as shall be necessary in addition to the following shall be at the discretion and judgment of the ICCFA's internal chief operating officer (COO), whose decisions and rulings shall be final in all cases, in addition to those explicitly enumerated herein. By signing the space application, the exhibitor agrees for itself and its representatives to abide by all such rules and regulations as well as the decision of the exposition management and the ICCFA internal COO in interpreting the same.

Acts of God The performance of this agreement by either the ICCFA or the exhibitor is subject to Acts of God, war, terrorism, government regulation, disaster, strikes, civil disorder, curtailment of transportation facilities or other emergencies making it inadvisable, illegal or impractical to provide the facilities or to hold the Annual Convention & Exposition. It is provided that this agreement may be terminated for any one or more such reasons by written notice from one party to the other without liability.

Advertising Suppliers are encouraged to promote their products and services in ICCFA Magazine, the official magazine of the ICCFA. Advertising packages and pricing can be obtained by calling 1.800.645.7700.

After-Hours Admission to the Exhibit Hall During show days, exhibitors are required to wear badges and may enter the hall one hour prior to the scheduled opening time of convention and exhibit activities and remain one hour after the scheduled closing time. Access to the exhibit hall at all other times must be approved by the internal COO of the ICCFA or a representative.

Booth Guidelines If an exhibitor is using its rental space in a manner that is detrimental to the Association, convention or exposition, or infringes on the rental of space by other exhibitors (including sight observation, soliciting products or services outside of the booths assigned, excessive noise, heat, light or pollution emanating from exhibits), or if an exhibitor's display is not in keeping with the

character and purpose of the show, the Association, through its internal COO, reserves the right to request corrective action. If an exhibitor is unable or refuses to comply with this request, the Association reserves the right to cancel the use for that space, or bar from the Exposition Hall that exhibit or any part of that exhibit, person or thing, and to remove the exhibit from the Exposition Hall. In the event that such action is necessary, the exhibitors shall forfeit all money paid or due the Association for rental of the booth space.

Cancellation of Booth Space The exhibitor shall give the ICCFA written notice of intention to cancel or withdraw from the exposition. In the event that notice is received by February 1, 2010, the exhibitor will receive a refund, except for the \$500 per booth deposit, which is non-refundable. In the event that notice is received after February 1, 2010, no refunds will be made and the canceling party will be liable for the entire rental fee in the event that the Association is unable to resell the space(s). Under no circumstances will the \$500 per booth deposit be refunded.

Cancellation, Interruption, or Postponement of the Exposition In the event that the Exposition is canceled, interrupted or postponed due to any occurrence not occasioned by the conduct of the ICCFA, whether such occurrence be, but not limited to, an Act of God, or the result of war, terrorism, riot, civil commotion, strikes, sovereign conduct or by any other cause, or if circumstances make it impossible or impractical for the ICCFA to permit any exhibitor to occupy the premises, the ICCFA shall make a good faith effort to adjust the rental fee for space based on the period of time the space was or could have been occupied by such exhibitor, and the ICCFA is released from any and all claims for damages which may arise in consequence thereof.

Care of Building No exhibitors shall allow any article to be brought into or any act done on the premises that will increase the premiums on or void the policies of insurance held on the building, or injure or deface any part of the building, or permit anything to be done by its representatives or employees by which the premises shall in any manner be damaged, marred or defaced.

Children Children (minors under the age of 18) are not allowed on the exhibit floor during setup or tear down.

Cumulative Point System Exhibitors accrue five points for their first booth rented each year and one additional point for each booth rented in excess of one per year. Exhibitors accrue one point for each table on display utilized at ICCFA's former Cemetery Operations & Maintenance Conference and the Annual Convention & Exposition.

Points are awarded for advertising placed in ICCFA Magazine as follows: 2 points for ads larger than ½ page, 1 point for ads ½ page or smaller; 1 point for ads placed in the ICCFA Membership Directory & Buyers' Guide. Advertising points accrued during the 12-month period of December 2008 through November 2009 will be credited toward the 2010 point system. The ICCFA also recognizes our conference and Convention sponsors with points, at a rate of ½ point per \$1,000 in sponsorship, beginning with sponsorships contributed in 2008.

Booth assignment points will be credited only to the entity or person that earned the points and cannot be shared with or assigned to another entity or person.

A person or entity owning more than one operation or organization may apply for and rent booth space under its own name and permit its component organizations or entities to use that space. However, the point total used for assignment of space will be based solely on the points earned by the owning or controlling person or entity and will not include points earned by its components or members. Identifiable components may apply for and rent space under their names, rather than the name of the person or entity controlling the component, and have assignments made based on the component point total.

If two entities merge or combine, the surviving organization or operation will receive the higher of the two point totals, but not the combined totals.

Exhibit Hall Passes Exhibitors wishing to bring visitors to the convention or into the exhibit hall may purchase Exhibit Hall Session Passes for \$45 at the ICCFA's Registration Desk. Please note that guests using these passes may only visit the exhibit hall and not any of the educational sessions, and may visit the hall only for that one specific session or time period. These passes are not intended for use by exhibiting personnel.

Rules of the Expo (continued)

Exhibitor's Profile The Booth Space Application & Contract included in this mailing requests that each exhibiting company provide the ICCFA with a descriptive profile detailing the product, service or history of the company for inclusion in the March/April onsite convention issue of ICCFA Magazine. The description should be brief and factual and must be submitted by January 15, 2010.

Exhibitor Representatives Each exhibiting company shall assign at least one person to be its representative in connection with the installation, operation and removal of its exhibit. The representative shall be the agent of the exhibitor and shall have the authority to enter into this agreement and such service contracts as may be necessary, on behalf of the exhibitor.

All business between the ICCFA and the exhibitor will be conducted only through the latter's designated representative and no other person. Exhibitors desiring to change representatives must notify the Association in writing. Two complimentary registrations are provided with each booth. All exhibit personnel must register for the ICCFA Convention and Exposition. An Exhibitor Personnel Registration Form is enclosed. In order for the name of a representative and exhibiting company to appear in the convention pre-registration directory, the pre-registration form must be received by February 1, 2010.

Exhibitors will be provided identification badges in accordance with exhibitor convention registration policy. Badges will not be transferable and will be required for admittance to the Exposition Hall. To be permitted entrance to the Exposition Hall, an organization or person(s) supplying goods and services to the cemetery, funeral service, cremation and memorialization industry must have contracted for booth space. Non-exhibiting firms and/or persons will not be permitted to conduct promotional or sales activities in the Exposition Hall. Anyone violating this policy will be escorted from the Exposition Hall and their registration credentials may be revoked.

Fire Regulations Exhibitors agree to adhere to all Exposition Hall fire regulations in designing, setting up and operating their exhibit. Gasoline or other flammable materials shall not be permitted in the Exposition Hall unless essential to either display or exhibit. In no case shall gasoline or other flammables be stored in the halls.

Force Majeure If any part of the Henry B. Gonzalez Convention Center is destroyed or damaged by any cause that renders the

holding of this Exposition impractical, the performance of this agreement is excused. However, exhibitors shall be liable for all fees due under this agreement which have accrued as of the time of termination. However, if such lack of performance is due to the acts or omissions of any exhibitor, then the party responsible for such acts or omissions shall be liable for the full amount hereunder in addition to charges for related claims and damage. Exhibitor hereby waives any claim for damages or compensation from the ICCFA or Henry B. Gonzalez Convention Center on account of such termination.

George Fern Co. Service Center A George Fern Co. representative will be available at the Service Desk during move-in and move-out times, all show hours as well as one hour prior to and one hour after the scheduled show hours, to address questions regarding orders and other services.

Hanging Signs and Other Materials Exhibitors wishing to hang signs or other materials over their booth(s) must submit a written request to the attention of ICCFA's Show Manager and Maggie Lewis at George Fern Co. for approval thirty (30) days prior to the convention.

Installation and Dismantling Exhibitors will be permitted to begin assembling their exhibits at 8 a.m. Tuesday, March 9. In all cases, booths must be substantially set up by 4 p.m. Wednesday, March 10, for inspection by the ICCFA internal COO and/or the designated exposition manager to ensure compliance with the rules and regulations set forth in this prospectus.

In the event an exhibit has not been properly set up by that time, the ICCFA reserves the right to remove unsightly materials or to cover them in an appropriate manner at the exhibitor's expense.

Exposed unfinished sides or exhibit backgrounds must be draped to present an attractive appearance. The exhibit will be inspected during the set-up time and the decorator, with the approval of the show manager, will provide draping as deemed necessary. Any charges incurred will be the responsibility of the exhibitor.

No set-up will be permitted during Exposition hours. Exhibitors who plan to hire the services of another exhibit service firm (other than the official service contractor, George Fern Co.) must abide by the following rules:

1. They must notify ICCFA by February 1, 2010, of the name, address and telephone number of the service firm,

and the name of the supervisor in attendance.

2. The service firm must notify ICCFA by February 1, 2010, of the names of all exhibiting companies for which it has orders and the names of all employees working on the show, and furnish proof that adequate insurance is maintained to cover possible liabilities.
3. Upon arrival at the exposition site, service companies must check in at the Exhibitor Registration Booth to receive permits to work on the exposition floor. The unpacking, assembly and dismantling of displays and equipment may be done by employees of the exhibiting company. George Fern Co. will have skilled craftsmen available to perform these services if needed. Arrangements for all temporary labor should be made through George Fern Co. Official labor order forms are included in the Exhibitor Service Kit.

Please Note: Exhibitors bringing extra unregistered staff personnel to the site for the purpose of setting up their booth must furnish ICCFA with a list of all such personnel five weeks prior to the show (February 1). Temporary badges (good only for move-in and move-out) will be issued on-site. Unregistered booth personnel not appearing on the list will not be permitted entry to the Exposition Hall.

Dismantling All exhibits must be removed from the exhibit area by the exhibiting company at its own expense no later than 7 p.m., Friday, March 12. If an exhibitor fails to remove its exhibit on this day, the ICCFA may remove such exhibit to a storage warehouse at the risk and expense of the exhibitor, who shall pay any damage or expense incurred by the Association in removing the exhibit. No exhibit or part of an exhibit may be removed from the space allocated during the period of the exposition, except in cases of extreme necessity. Permission for such removal must be obtained from the internal COO of the ICCFA or a designated representative. Any exhibit torn down prior to official closing time without permission from the internal COO of the ICCFA or a designated representative will not accrue points for the current year.

Insurance Exhibitors must make provisions for the safekeeping of their goods before, during and after the ICCFA Exposition. Neither the ICCFA nor the management of the Exposition Hall shall be responsible for any injury which may occur to an exhibitor

Booth Space Application & Contract

ICCFA ANNUAL CONVENTION & EXPOSITION | March 10-13, 2010

Company Information

(Due December 1, 2009, for assignment under the cumulative point system.) Please provide information about your company below. Use the Exhibitor Personnel Registration form on pp. 13-14 to register individuals.

Exhibiting Company Name _____
 Address _____
 City _____ State/Prov _____ Zip/Postal Code _____
 Other/additional (addresses outside USA) _____
 Phone () _____ Fax () _____
 Email address _____ Web site _____
 Person Completing Form _____ (Please fill out both sides of form.)

Booth Selection and Fees

Application is to be accompanied by \$500 per booth non-refundable deposit to be eligible for assignment. All applications received by December 1 will be assigned based on ICCFA's point system. All other applications will be assigned on a first-come, first-served basis.

Booth Selections (see Expo floor plan on page 5)

1st choice: _____ 2nd choice: _____ 3rd choice: _____ 4th choice: _____ 5th choice: _____ 6th choice: _____

Number and type of booths requested

ICCFA MEMBER

of conventional booths _____ @ \$1,095 each = \$ _____

of premier booths _____ @ \$1,395 each = \$ _____

NON-MEMBER

of conventional booths _____ @ \$1,395 each = \$ _____

of premier booths _____ @ \$1,695 each = \$ _____

TOTAL COST OF EXHIBITION SPACE: \$ _____ TOTAL ENCLOSED (minimum of \$500 per booth*) \$ _____

*Full payment due by February 1. Any balance remaining on total due will be charged on February 1 to credit card provided.

Payment Information

Check: (Please make payable to ICCFA)

Credit Card: DISCOVER VISA MASTERCARD AMERICAN EXPRESS

Credit card number _____

Name as it appears on credit card _____ Exp. Date _____

Security ID (3-digit # on back of card or 4-digit # on front of AmEx card) _____

Card holder's billing address/ZIP _____

Signature _____

Authorized Representative

The following individual will serve as the authorized representative of the company listed above regarding the 2010 ICCFA Exposition. This person will receive all exhibit-related mailings regarding the Exposition.

Name of authorized representative _____

Address (if different from above) _____

I have read the rules and regulations pertaining to the 2010 ICCFA Exposition and agree that all representatives and exhibiting personnel from my company will comply with them.

Signature of authorized representative _____

Please Complete Side 2

For Official Use Only

Date Rec'd	Co. ID #	Check #	Points as of 11/09	IMSA
Total due \$	Deposit \$	Balance due \$	Booth #s	

Booth Space Application & Contract (continued)

Exhibit Specifications

Height at highest point _____

Dimensions (depth x width) _____ x _____

Weight (maximum) _____

Competition Proximity

The ICCFA will make every effort to comply with your request to be close to or separated from specific companies. However, this may not always be possible. The ICCFA will have final authority on booth assignments. Please list names of specific companies, not categories.

We wish to be close to the following companies: _____

We wish to be separated from the following companies: _____

Exhibitor Bonus: Free Exposure to 7,200+ ICCFA Magazine Readers!

The March-April issue of the ICCFA's magazine, ICCFA Magazine, will include profiles of all exhibitors who meet the submission guidelines and deadlines (below). The magazine will be available onsite at the ICCFA Convention & Exposition in Las Vegas and will be mailed to ICCFA members and to thousands of independent cemetery, crematory & funeral home owners nationwide.

We'll run your company's logo...

...or a photo of your company's product

Axiom Business Systems (#114)

Axiom is the leading developer of fully integrated funeral home, cemetery management and cemetery mapping software with accounting solutions in the Southeast Pacific.



Visit our booth for your free koala bear, Australian flag and demo.

www.charoncms.com

Cherokee Casket Co. (#417)

Cherokee Casket Co. has manufactured infant and child caskets since 1941.

The complete picture catalog can be seen online at www.cherokeechildcaskets.com.

1.800.535.8667



Use your 60 words to describe your company, attract people to your booth and tell readers who can't attend the ICCFA Convention how to get more information about you!

Profile submission deadline: January 15, 2010

Profile copy (maximum 60 words). The ICCFA reserves the right to edit all copy to comply with editorial guidelines and length specifications. You may submit by:

- E-mailing your profile to sloving@iccfa.com. Please write "[Company Name] Profile for ICCFA Magazine" in the subject line. If you would like to rerun your 2009 profile, you must send an e-mail requesting that we do so. Please say "include logo/photo" if you ran a logo or photo with your 2009 profile and want to rerun it with the 2010 profile. (You can check your 2009 profile and logo/photo by downloading the file at www.iccfa.com/files/Profiles_rules.pdf.)

Profile logo or photo—must be high resolution (at least 300 dpi at print size).

- E-mail your logo or photo to sloving@iccfa.com. If sent separately from the copy, please write "[Company Name] Logo/Photo for ICCFA Magazine profile" in the subject line.
- If you want us to use the logo/photo we ran in 2009, please indicate this on the profile copy or via a separate e-mail. We will not include the art unless requested, since we do not want to risk running a logo you are no longer using. (You can check your 2009 profile and logo/photo by downloading the file at www.iccfa.com/files/Profiles_rules.pdf.)

Submit Registration

Please mail this form with payment to: International Cemetery, Cremation and Funeral Association
107 Carpenter Drive, Suite 100, Sterling, VA 20164

Or fax both sides to: 703.391.8416

Form and deposit are to be received by December 1, 2009, for booths to be assigned under the cumulative point system. Balance is to be paid in full by February 1, 2010. Questions? Please call 1.800.645.7700.

Exhibitor Personnel Registration Form

ICCFA ANNUAL CONVENTION & EXPOSITION | March 10-13, 2010

Company Information (Due February 1, 2010)

Please provide information about your company below.
Use the back of this form to register individuals.

Exhibiting Company Name _____
 Address _____
 City _____ State/Prov _____ Zip/Postal Code _____
 Other/additional (addresses outside USA) _____
 Phone () _____ Fax () _____
 Email address _____ Web site _____
 Person Completing Form _____ (Please fill out both sides of form.)

Registration Fees

Payment is to accompany the registration form to receive discount for early registration.

Additional Registrations*: _____ @ \$320 each (\$350 after February 1) = \$ _____
 (In addition to the two-per-booth complimentary registrations.)
 Spouse/Guest Registrations*: _____ @ \$195 each = \$ _____

Total Registration Fees: \$ _____

Ticketed Events:

Prayer Breakfast: _____ tickets @ \$40 each = \$ _____
 Closing Dinner/Dance _____ tickets @ \$95 each = \$ _____

Total Ticketed Events: \$ _____

TOTAL ENCLOSED: \$ _____

Payment Information

Check: (Please make payable to ICCFA)

Credit Card: DISCOVER VISA MASTERCARD AMERICAN EXPRESS

Credit card number _____
 Name as it appears on credit card _____ Exp. Date _____
 Security ID (3-digit # on back of card or 4-digit # on front of AmEx card) _____
 Card holder's billing address/ZIP _____
 Signature _____

*Registration Includes: Daily admission to the Exhibit Hall and Convention Program Sessions and all Exposition Hall food functions.
(Spouse/Guest registration includes Closing Dinner/Dance.)

Cancellation Policy: Registrants canceling their registrations by February 1, will receive a refund. All cancellations must be in writing and are subject to a \$50 per person processing fee. Ticketed events will be refunded less a \$5 processing fee per event. Cancellations received after February 1, will not result in refunds.

Please Complete Side 2

For Official Use Only

Date Rec'd	Co. ID #	Booth #s
Total due \$	Check #	Balance due \$

Exhibitor Personnel Registration Form (continued)

Attendees

Please use the space below for each individual your company is registering. All exhibitors must be registered for this Convention, including the two-per-booth complimentary registrants. Registrations received by February 1 will have their names included in the Exhibitor's Directory. (Please make additional copies of this form if needed.)

1. Name: _____ Badge name: _____ Complimentary
 Spouse/Guest* _____ Badge name: _____ Fee: _____
 Address (if different from reverse) _____
 Phone (if different from reverse) _____
 Ticketed Events** _____ Prayer Breakfast _____ Closing Dinner
 (Write in number needed. Spouse/Guest registration includes tickets for Dinner.)

2. Name: _____ Badge name: _____ Complimentary
 Spouse/Guest* _____ Badge name: _____ Fee: _____
 Address (if different from reverse) _____
 Phone (if different from reverse) _____
 Ticketed Events** _____ Prayer Breakfast _____ Closing Dinner
 (Write in number needed. Spouse/Guest registration includes tickets for Dinner.)

3. Name: _____ Badge name: _____ Fee: _____
 Spouse/Guest* _____ Badge name: _____ Fee: _____
 Address (if different from reverse) _____
 Phone (if different from reverse) _____
 Ticketed Events** _____ Prayer Breakfast _____ Closing Dinner
 (Write in number needed. Spouse/Guest registration includes tickets for Dinner.)

4. Name: _____ Badge name: _____ Fee: _____
 Spouse/Guest* _____ Badge name: _____ Fee: _____
 Address (if different from reverse) _____
 Phone (if different from reverse) _____
 Ticketed Events** _____ Prayer Breakfast _____ Closing Dinner
 (Write in number needed. Spouse/Guest registration includes tickets for Dinner.)

If you have any special needs due to a disability, please check here and attach a statement of your needs.

* Guests are persons from outside the cemetery, funeral service and related professions accompanying a registrant.

** Total number of tickets noted should match number purchased on reverse side.

Submit Registration

Please mail this form with payment to: International Cemetery, Cremation and Funeral Association
 107 Carpenter Drive, Suite 100, Sterling, VA 20164

Or fax both sides to: 703.391.8416

Questions? Please call 1.800.645.7700

Rules of the Expo (continued)

or its representatives or employees, nor for the safety of any exhibit or other property against robbery, fire, accident or any other destructive cause. Insurance, if desired, shall be taken out by the exhibitor, who hereby agrees to hold the ICCFA harmless and free from all damages or liabilities of any kind.

Liability The exhibitor, on its own behalf and on behalf of its employees and agents, assumes entire responsibility and hereby agrees to protect, indemnify, defend and save the ICCFA, Henry B. Gonzalez Convention Center, the official service contractor, and its employees and agents harmless against all claims, losses and damages to persons or property, governmental charges or fines, and attorneys' fees arising out of or caused by exhibitors' installation and removal, maintenance, occupancy or use of the exposition premises or part thereof, excluding any such liability caused by the sole negligence of Henry B. Gonzalez Convention Center, the official service contractor, its employees and agents.

In addition, the exhibitor acknowledges that the ICCFA and Henry B. Gonzalez Convention Center do not maintain insurance covering exhibitor's property and that it is the sole responsibility of the exhibitor to obtain business interruption and property damage insurance covering such losses by the exhibitor. All exhibitors are encouraged to obtain all risk coverage. This can be done by riders to existing policies, often at no extra cost.

Outside Exposition and Activities During scheduled convention activities the exhibitor agrees, subject to expulsion from the show and its firm from convention functions and activities, not to exhibit its products or services or to directly promote or otherwise exploit its company, products or services outside the Exposition Hall. Exhibitor also agrees not to entertain convention attendees during exposition or convention program hours in a rental function room, hospitality suite or other rented facility, or otherwise induce attendees away from the show or scheduled convention events.

Payment Schedule Each application for exhibit space must be accompanied by a non-refundable deposit of \$500 per booth and received by December 1, 2009, to be eligible for assignment under the cumulative point system (see Assignment of Exhibit Space, page 7). Full payment for exhibit space is due February 1, 2010. If the balance on the booth payment is not

received by February 1, 2010, the ICCFA reserves the right to charge it against credit card on file. Failure to pay the rental fee in full by this date will result in an automatic cancellation of this agreement. Under no circumstances will an exhibitor be allowed to set up an exhibit unless full payment of the rental booth(s) space has been received.

Protection of Employees and Property Exhibitors agree to release and to protect and hold harmless the ICCFA and its officers, directors and employees from any and all claims for damages, suits, etc.; for injuries to themselves, their representatives or employees; and for damage to property in their custody, owned or controlled by them, which claims for damages, suits, etc., may be incident to, arise from, grow out of or be connected with their use or occupation of space.

Protection of the Public Exhibitors must protect machinery and exhibits to ensure that no injury will result to the public, visitors, guests, employees or any other person or property. Exhibitors agree to protect and hold harmless the ICCFA and its officers, directors and employees for any and all claims which may result on account of injury, loss or damage sustained upon the space occupied by the exhibitors respectively, or on account of machinery and property under the control of such exhibitors or on account of negligence of exhibitors, their representatives, employees or agents.

Security Service The ICCFA will provide security on a 24-hour basis beginning at 8 a.m. on Tuesday, March 9, and concluding at 7 p.m. on Friday, March 12, but neither the Association nor Henry B. Gonzalez Convention Center will guarantee the exhibitors against loss or assume responsibility for fire, theft or other damage of any sort.

Smoking Policy The ICCFA has designated the exhibit hall a non-smoking area. Smoking will not be permitted any time during move-in, move-out or during dates of the convention.

Soliciting by Non-Exhibitors Soliciting in any manner within the Exposition Hall by any supplier, individual, group, company or firm, within or outside the industry, is strictly forbidden unless said person, group or firm has contracted for rental of booth space with the ICCFA. Any person, group or firm that has not contracted for booth space but is found soliciting in the Exposition Hall or elsewhere in the convention hotel will be required to forfeit their convention badge(s) to the Association and will be barred from

the Exposition Hall, from all meeting and function rooms and other areas being used by the Association, and from all official activities of the convention. Those forfeiting convention badges will not be entitled to refunds of any registration fees or other monies paid to the Association.

To be permitted to conduct promotional or sales activities in the Exposition Hall, an organization or person(s) supplying goods and services to the cemetery, funeral service, cremation and memorialization industry must have contracted for booth space. Non-exhibiting firms and/or persons will not be permitted to conduct promotional or sales activities in the Exposition Hall. Anyone violating this policy will be escorted from the Hall and their registration credentials revoked.

Spanning Aisles No exhibit will be permitted to span an aisle by ceiling or floor covering.

Subletting Space No exhibitor shall assign, subject or apportion the whole or any part of the space allotted to it, nor exhibit therein, nor permit any other person or party to exhibit therein, any goods other than those manufactured or handled by the exhibitor in the regular course of its business.

Unoccupied Space The ICCFA reserves the right to rent to any other exhibitor previously rented but unoccupied space after 1 p.m. on the opening date of the Exposition. Moreover, this clause shall not relieve the exhibitor who contracted for the booth space of the financial obligations to pay the full amount, or any portion thereof, of said rental fee, in the event that the ICCFA is unable to rent the space at the same rental rate as agreed to by the entity originally assigned the space.

Use & Care of the Exhibitor's Space Exhibitors agree that all products to be displayed are suitable to the cemetery, funeral service, cremation and memorialization industry. Booth space will be used only for display purposes and soliciting in the aisles will not be permitted. Each exhibitor shall care for, keep in good order and surrender the space occupied by it in the same condition as it was at the commencement of the occupation, ordinary wear expected. Daily maintenance is the responsibility of the exhibitor and not included in the cost of booth space. However, vacuuming service may be ordered through George Fern Co.

THE NEXT STEP

2010 ICCFA ANNUAL CONVENTION & EXPOSITION
HENRY B. GONZALEZ CONVENTION CENTER • SAN ANTONIO, TX
MARCH 10-13, 2010

Exhibitor Deadlines

November 2009

- November 25 Deadline for reserving advertising space in January 2010 Convention Program Issue of ICCFA Magazine.

December 2009

- December 1 Points earned from December 2008 to November 2009 applied toward 2010 booth assignments.
 Booth Space Application and Contract due to ICCFA (pp. 11-12) for assignment under cumulative point system, along with non-refundable deposit of \$500.
 Deadline for contacting the ICCFA to become an Annual Convention sponsor (p. 16).

January 2010

- January 15 Exhibitor Profiles due to ICCFA for inclusion in March/April 2010 Onsite Convention Issue of ICCFA Magazine. Submit logo or photo with your profile.

February 2010

- February Registered exhibitors will receive Service Kits via e-mail from George Fern Company.
February 1 Full payment for booth space due to ICCFA. No refunds for booth cancellations received after this date. Cancellations received in writing by February 1 will receive a refund less the \$500 non-refundable deposit.
 Booth Space Application & Contract due to ICCFA (pp. 11-12) to appear in Exhibitor's Directory.
 Exhibitor Personnel Registration Form due to ICCFA (pp. 13-14) .
February 10 Deadline for reserving advertising space in March/April 2010 Onsite Convention Issue of ICCFA Magazine.
February 18 Deadline for hotel reservations at Grand Hyatt San Antonio.

March 2010

- March 10 By 1:00 p.m.—All exhibiting companies are to physically claim booth space.
 By 4:00 p.m.—Booths set up according to IAEM/EDPA regulations and ready for ICCFA inspection. (First Timers Reception at 5:30 p.m. and Grand Opening at 6:00 p.m.)
March 11 9:00 - 10:00 a.m.—IMSA Business Meeting.
March 12 3:00 p.m.—Begin tear-down and move-out.

April 2010

- April 7 Deadline for reserving advertising space in May 2010 Post-Convention Coverage Issue of ICCFA Magazine.

ICCFA Magazine provides excellent opportunities to reinforce your company's marketing strategy. Read by 7,200+ industry decision makers, ICCFA Magazine's recognized highest-quality editorial content ensures strong reader interest—including everyone who will attend the Expo.

For complete pricing information and to place an insertion order, please call ICCFA Supplier Relations Manager Rick Platter at 1.800.645.7700. The deadline to reserve space for the 2010 Convention Program Issue (January 2010)—which will have a bonus circulation of 14,000+ issues—is November 25.

TAKE THE NEXT STEP!

Become a Sponsor!

Put your company in the spotlight by participating as an Annual Convention & Exposition sponsor. Sponsorships are available at a wide range of levels. Sponsors will be recognized:

- in the Convention onsite program
- on signage
- in the March/April Onsite Convention Issue of ICCFA Magazine.
- on staging screens
- in announcements made from the podium
- and more!

For information on becoming a sponsor, please contact Nadira at 1.800.645.7700; nadira@iccfa.com

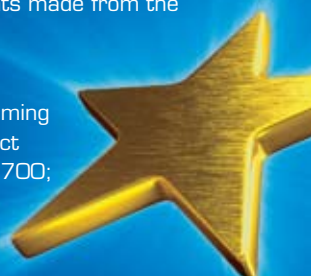

Expo Contact Information:

International Cemetery, Cremation & Funeral Association

Rick Platter
107 Carpenter Drive, Suite 100
Sterling, VA 20164
800.645.7700
Fax: 703.391.8416
rickp@iccfa.com

George Fern Co. (Decorator)
Maggie Lewis
125 Fernco Drive
Nashville, TN 37207
615.256.0357
Fax: 615.256.0490
mlewis@georgefern.com

Hotel Reservations

The ICCFA has secured a discounted rate of \$219 at the Grand Hyatt San Antonio. To reserve your room at our reduced rate, call 1.888.421.1442 and identify yourself as an attendee at the ICCFA Convention. The cutoff for hotel reservations is February 18, 2010; however, we expect our block to sell out, so be sure to make your reservations early.